

FLEXIBLE COUPLING DETAILS

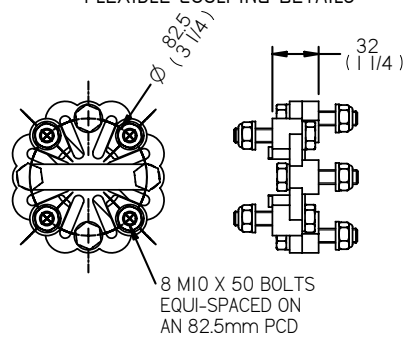

FLEXIBLE MOUNT DETAILS

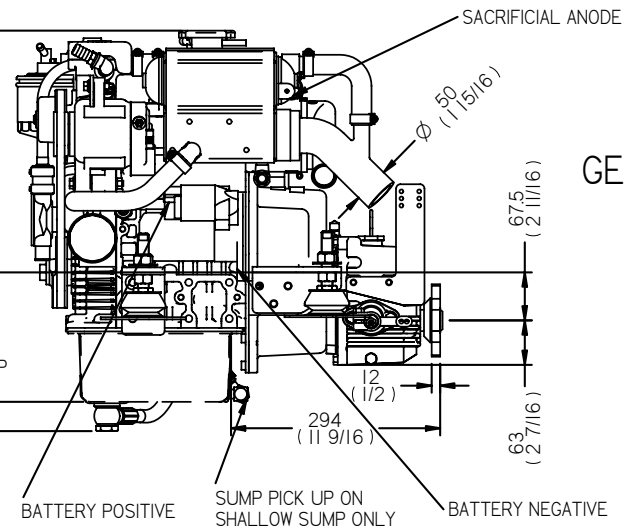
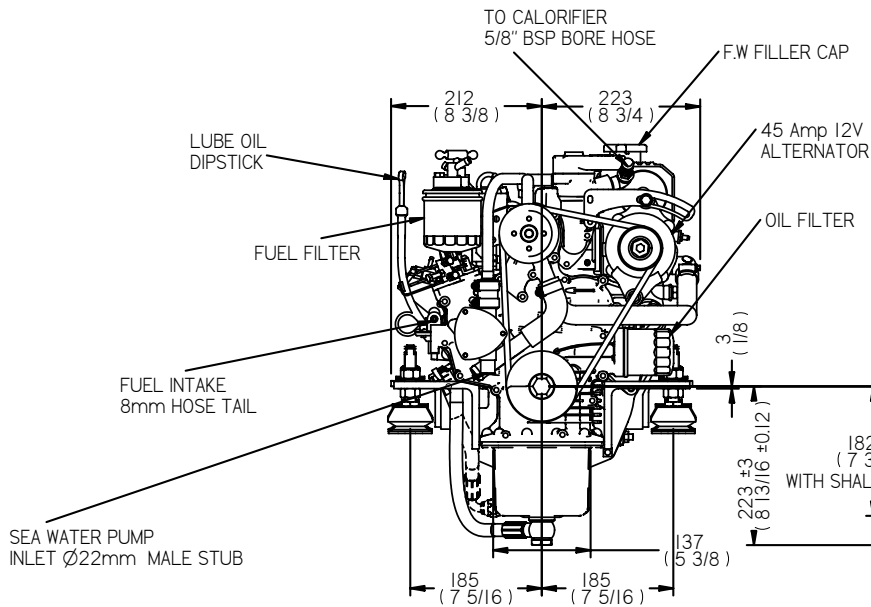
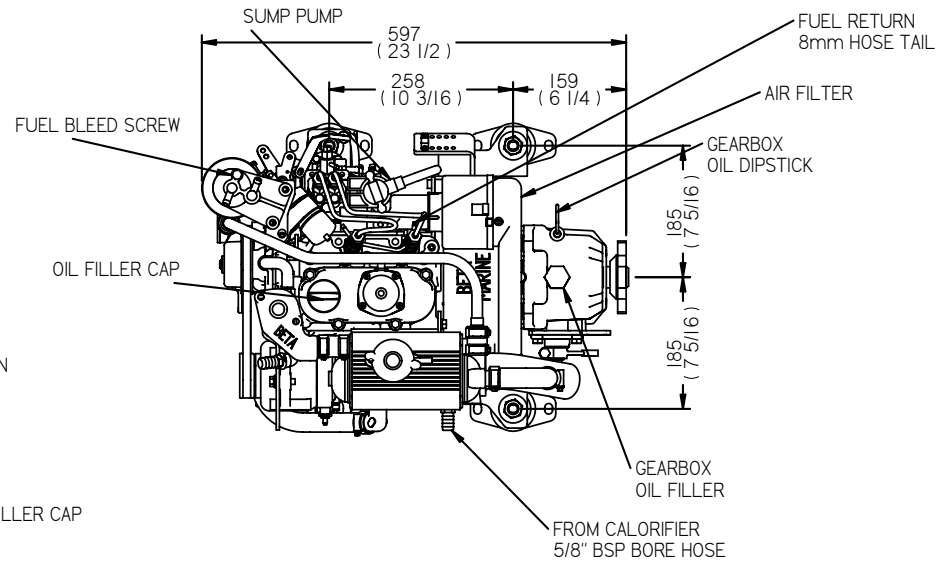
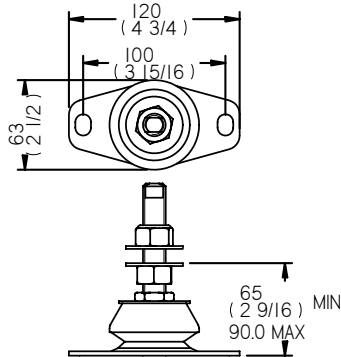

GEARBOX OUTPUT

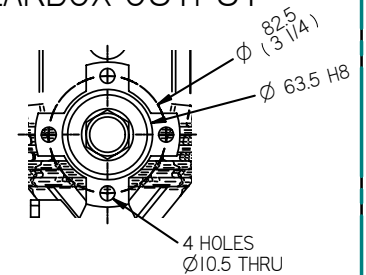

REV	DESCRIPTION	DATE	APP'D	DRAWN	NOTES
01					

DIMENSIONS IN MM (INCH)
DO NOT SCALE

BETA MARINE

TEL: (01453) 835282 FAX: (01453) 835284

BETA MARINE LTD.
MERRETT'S MILLS,
BATH ROAD,
SOUTH WOODCHESTER,
STROUD, GLOS. GL5 5EU

TITLE **BETA 16 (BZ602) HEAT EXCHANGE
TMC40 GEARBOX**

DRAWN BY:- timw	SIZE A4	DWG NO. 100-06496	REV 00
CHECKED BY:-	SCALE	PAGE 1 of 1	DATE 13/08/2007